

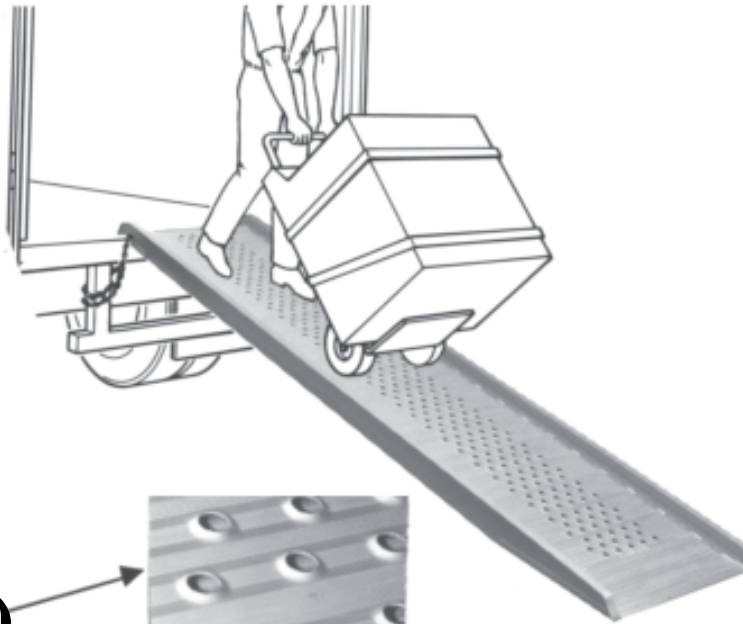

Modern Light Metals, Inc.
Coloma, MI 49038
Ph. 800-253-1505
Fax 269-468-4320

Aluminum Van Ramps



4 1/2" high rails, with 2 1/8" curb height, make ramps safer and stronger, especially for longer length ramps.

Tapered bottom at the lower end of ramp makes loading of heavy goods easier. No bump which is objectionable to many customers.

Serrated flooring gives good traction.

Optional -Perforated Decking is recommended for customers in Snow Belt Regions

AVR

Model:

Example Model No.
AVR 2914

overall width in inches

total length in feet

Standard Nose Style



Comes standard with a 6" lip and 40" long safety chains and grab hooks.

Optional Hook Nose



Deduct \$40 from list price. Slots must be cut in door sill to accommodate hooks. Provides solid locking.

Model Number	Useable Width inches	Length Feet	Capacity Lbs.	Minimum Height @ 5-1/2°	Rec. Maximum Height* 15-1/2°	Maximum Height @ 19°	Weight Lbs.	Price \$	Price with Perforations
AVR 296	26	6	2000	7	17	20	64	\$554	\$600
AVR 297	26	7	2000	8	20	24	73	\$598	\$651
AVR 298	26	8	2000	9	24	28	81	\$642	\$702
AVR 299	26	9	2000	10	27	32	90	\$687	\$753
AVR 2910	26	10	2000	11	30	35	98	\$731	\$804
AVR 2912	26	12	2000	14	36	43	115	\$836	\$922
AVR 2914	26	14	1700	16	43	51	132	\$933	\$1032
AVR 2916	26	16	1500	18	49	58	149	\$1021	\$1133
AVR 2918	26	18	1300	20	56	68	166	\$1110	\$1235
AVR 356	32	6	2000	7	17	20	72	\$586	\$632
AVR 357	32	7	2000	8	20	24	82	\$634	\$687
AVR 358	32	8	2000	9	24	28	91	\$683	\$742
AVR 359	32	9	2000	10	27	32	101	\$731	\$797
AVR 3510	32	10	2000	11	30	35	110	\$780	\$852
AVR 3512	32	12	2000	14	36	43	130	\$893	\$979
AVR 3514	32	14	1700	16	43	51	149	\$998	\$1097
AVR 3516	32	16	1500	18	49	58	168	\$1095	\$1207
AVR 3518	32	18	1300	20	56	68	187	\$1192	\$1318
AVR 416	38	6	2000	7	17	20	88	\$653	\$700
AVR 417	38	7	2000	8	20	24	98	\$705	\$760
AVR 418	38	8	2000	9	24	28	109	\$758	\$820
AVR 419	38	9	2000	10	27	32	120	\$811	\$877
AVR 4110	38	10	2000	11	30	35	130	\$863	\$936
AVR 4112	38	12	2000	14	36	43	152	\$985	\$1071
AVR 4114	38	14	1700	16	43	51	173	\$1099	\$1198
AVR 4116	38	16	1500	18	49	58	195	\$1204	\$1316
AVR 4118	38	18	1300	20	56	68	216	\$1309	\$1435

- NOTE:**
- Width shown is overall width, useable is 3" less on both the regular and economy Van Ramps. On models with perforations, perforations are in center 12 1/2" of ramp. This allows wheels of hand cart to go outside of perforations for smoother rolling.
 - Capacities shown are for 4 wheel trucks only. On 2 wheel trucks use 1/2 the listed capacity.
 - * Recommended Maximum Height is maximum height for day in day out use.
 - Van Ramps are **not** designed for pallet truck use.

*** Shipment 10-14 days

Freight Classification: Item 168720 Class 100 ***

Options

Longer lips available at additional charge. Add.. \$ 80.00 to list price.

& Economy Van Ramps



This ramp is made like our competitors Van Ramps. All ramps have the same serrated deck surface and are available with perforations just as our standard Van Ramp. **What makes these ramps different from our normal Ramps are the following features or lack of features:**

1. Bump at bottom of Ramp - Makes first 10 inches of ramp at a steeper slope. This makes it harder to get up the ramp with heavy loads.
2. Ends are cut off - Not rounded - More chance of tripping and scuffing shoes.

So if you are unloading and have minimal use requirements, the Economy Van Ramp may very well be your answer.

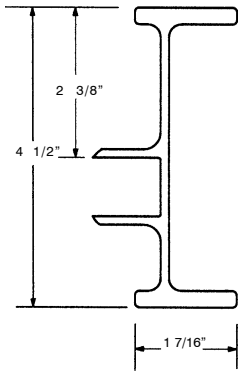

Side Rails

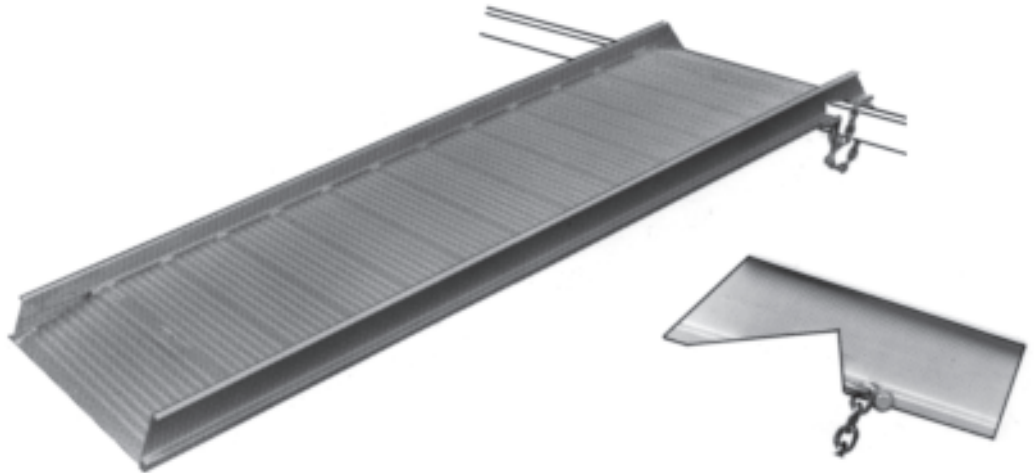

Now uses same rail as our Normal Van Ramp. The 4-1/2" high curb is stronger and will enable you to carry heavier loads with less deflection

Both Ramps are at 18 degree Slopes

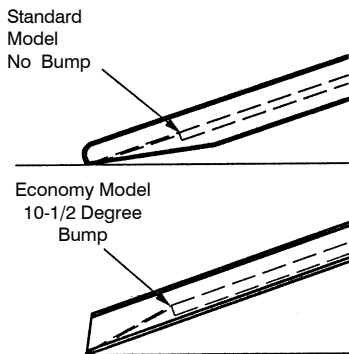

Bottom is not tapered as in our Standard Model.

This takes less time to manufacture and allows ramp to go down lower than our standard model. Only draw back is there is a 10-1/2 degree bump at the lower end and the ramp is now at a 28-1/2 degree slope on this bottom portion. This is objectionable when going up the ramp with heavy loads.

Model Number	Useable Width inches	Length Feet	Capacity Lbs.	Minimum Height @ 0°	Maximum Height @ 19°	Weight Lbs.	Price \$	Price with Perforations
EVR 296	26	6	2000	0	20	60	\$491	\$537
EVR 297	26	7	2000	0	24	69	\$536	\$589
EVR 298	26	8	2000	0	28	78	\$582	\$641
EVR 299	26	9	2000	0	32	87	\$627	\$693
EVR 2910	26	10	2000	0	35	96	\$673	\$746
EVR 2912	26	12	2000	0	43	113	\$774	\$860
EVR 2914	26	14	1700	0	51	131	\$873	\$972
EVR 2916	26	16	1500	0	58	149	\$965	\$1077
EVR 356	32	6	2000	0	20	68	\$523	\$569
EVR 357	32	7	2000	0	24	78	\$572	\$625
EVR 358	32	8	2000	0	28	88	\$622	\$682
EVR 359	32	9	2000	0	32	98	\$672	\$738
EVR 3510	32	10	2000	0	35	108	\$722	\$794
EVR 3512	32	12	2000	0	43	128	\$831	\$917
EVR 3514	32	14	1700	0	51	148	\$939	\$1038
EVR 3516	32	16	1500	0	58	168	\$1039	\$1151
EVR 416	38	6	2000	0	20	84	\$590	\$636
EVR 417	38	7	2000	0	24	95	\$643	\$696
EVR 418	38	8	2000	0	28	106	\$697	\$757
EVR 419	38	9	2000	0	32	117	\$751	\$817
EVR 4110	38	10	2000	0	35	128	\$805	\$878
EVR 4112	38	12	2000	0	43	150	\$923	\$1009
EVR 4114	38	14	1700	0	51	172	\$1039	\$1139
EVR 4116	38	16	1500	0	58	194	\$1147	\$1260